

**BT121 BLUETOOTH DUAL MODE MODULE**  
DATA SHEET

Wednesday, 25 November 2020

Document Version: 1.62



## VERSION HISTORY

Date Edited	Comment
1.0	First release of document
1.1	Minor updates
1.2	Minor updates
1.3	Power consumption measurements
1.4	Revised power consumption measurements
1.41	FCC, IC, Japan and Korea certification info updated
1.42	Various corrections and edits, corrected front page +10dBm LE power number and RF specification +9dBm both to the +7dBm setting used in the module for regulatory compliance
1.43	Wake-up pin section added
1.44	Mass production part numbers added to ordering code list.
1.45	Typo corrections related to the note concerning I2C 2. I2C 2 can be used only in Alt 2 configuration.
1.46	Certificates section under FCC separation between human body and antenna changed from 9 mm to 7 mm. SWD bus clarification : PA13 = SWDIO and PA14 = SWCLK
1.47	Altered outline and footprint drawings to render properly in PDF
1.48	Sleep mode current updated
1.49	Reset description elaborated, fixed I2C schematic, added number of piconets, wake-up sources corrected
1.50	Fixed SPI slave select descriptions
1.51	SDK and SDA pins in Figure 21 corrected to SCL and SDA with correct placement
1.52	Minor changes
1.53	Contact information updated
1.6	Added dimension details for the 8 center pads for programming and testing Editorial and layout fixes

1.61	Corrected the maximum number of simultaneous connections Corrected Bluetooth version compliance
1.62	Renamed "Smart Ready" to "Dual Mode" and "Classic" to "BR/EDR" according to the official Bluetooth SIG nomenclature.

## TABLE OF CONTENTS

<b>1</b>	<b>BT121 overview</b>	<b>7</b>
1.1	Key Features	7
1.2	Typical applications	8
1.3	Block diagram	8
<b>2</b>	<b>Design guidelines</b>	<b>9</b>
2.1	PCB layout recommendations	9
2.2	Power supply recommendations	9
2.3	Software application related options	9
2.4	Firmware updating related recommendations	9
<b>3</b>	<b>Pin-out description</b>	<b>11</b>
3.1	Power, ground, reset, RF and boot loader pins	11
3.2	GPIO pins	12
<b>4</b>	<b>Power control</b>	<b>13</b>
4.1	Power supply requirements	13
4.2	Power saving functionality	13
4.3	Reset	14
4.4	Recovery mode	15
4.5	Clock signals	15
<b>5</b>	<b>Interfaces</b>	<b>16</b>
5.1	GPIO	16
5.2	UART	17
5.3	I <sup>2</sup> C	17
5.4	SPI	17
5.5	ADC	17
5.6	DAC	17
5.7	Real-time clock	17
5.8	Microcontroller programming interface	17
<b>6</b>	<b>Antenna</b>	<b>18</b>
6.1	Effect on antenna matching of a plastic sheet placed near the antenna	18
6.2	Effect on antenna matching of a metal sheet placed under the antenna	20
6.3	Effect on antenna matching of a metal sheet placed against the end of the module	21
6.4	Measured antenna efficiency	22
6.5	Measured 2D radiation patterns	23
6.6	Measured 3D radiation patterns	25
<b>7</b>	<b>Bluetooth Stack Software</b>	<b>26</b>
<b>8</b>	<b>Host interface</b>	<b>27</b>

8.1	UART	27
<b>9</b>	<b>Connection examples</b>	<b>28</b>
9.1	Connecting an external host using the UART interface	28
9.2	Connecting an external device using SPI interface	29
9.3	Connecting an external device using I <sup>2</sup> C interface	30
<b>10</b>	<b>Electrical characteristics</b>	<b>31</b>
10.1	Absolute maximum ratings	31
10.2	Recommended operating conditions	31
10.3	Logic signal characteristics	32
10.4	Power consumption	34
<b>11</b>	<b>RF Characteristics</b>	<b>36</b>
11.1	Supported frequencies and channels	36
11.2	Typical receiver sensitivity	36
11.3	Transmitter output power	36
11.4	Carrier frequency accuracy	36
<b>12</b>	<b>Physical dimensions</b>	<b>37</b>
<b>13</b>	<b>Soldering recommendations</b>	<b>39</b>
13.1	Soldering profile example	40
<b>14</b>	<b>Tape and reel packaging</b>	<b>41</b>
14.1	Reel material and dimensions	41
14.2	Tape material and dimensions	41
14.3	Tape and reel box dimensions	42
14.4	Module orientation in tape	42
<b>15</b>	<b>Certifications</b>	<b>43</b>
15.1	Bluetooth	43
15.2	CE	43
15.3	FCC	43
15.4	IC	44
15.5	MIC Japan	46
15.6	KC (South-Korea)	46
<b>16</b>	<b>Ordering information</b>	<b>47</b>
<b>17</b>	<b>Contact Information</b>	<b>48</b>

# 1 BT121 overview

BT121 is a Bluetooth Dual Mode module targeted for applications that require both Bluetooth LE and BR/EDR connectivity. It can connect to legacy devices that only support Bluetooth SPP or Apple® iAP2 profiles as well to devices that support Bluetooth LE. BT121 integrates a high performance Bluetooth radio, a low-power ARM Cortex micro-controller and a Bluegiga Bluetooth Dual Mode stack software making it extremely easy-to-use as no RF or Bluetooth software development is needed. BT121 can be used as a modem together with a separate host MCU, but applications can also be embedded into the built-in ARM® Cortex® MCU with the Bluegiga BGScript™ scripting language.

## 1.1 Key Features

### Bluetooth features

- Bluetooth 4.1 Dual Mode compliant
- Master and slave modes
- Up to 6 x BR/EDR connections
- Up to 7 x BLE connections
- 1 x BR/EDR + 6 x BLE connections simultaneously
- Scatternet: 3 simultaneous piconets, 1 as master + 2 as slaves

### Radio features

- Integrated antenna
- TX Power
  - +12 dBm with Bluetooth BR/EDR
  - +8 dBm with Bluetooth LE
- RX Sensitivity
  - -96 dBm
- 200-400 meter LoS range

### Software features

- Integrated Bluetooth Dual Mode Stack
- SPP, iAP2, HID and GATT over BR Bluetooth profiles
- Any GATT based Bluetooth LE profile
- 1000 kbps throughput over SPP
- BGAPI™ serial protocol API over UART for network co-processor usage
- BGLIB™ host C library which implements BGAPI serial protocol
- BGScript™ scripting language for standalone usage
- Profile Toolkit™ for creating GATT based services

### Hardware interfaces

- UART host interface
- 2 x SPI, UART and 2 x I2C peripheral interfaces
- Up to 22 x GPIO with interrupts
- 4 x 12-bit ADC
- Internal battery voltage measurement option

### Microcontroller

- ARM Cortex M0
- 48 MHz
- 16kB RAM
- 128kB flash

### Electrical characteristics

- Supply voltage: 2.2V to 3.6V
- Supply voltage: 2.4V to 3.6V when using ADC

### Environmental and regulatory

- Temperature range: -40C to +85C
- Bluetooth, CE, FCC and IC, Japan and South-Korea qualified

### Dimensions:

- 11.0 mm x 13.9 mm x 2.2 mm (W x L x H)

## 1.2 Typical applications

BT121 can be used in a wide variety of applications such as cable replacement, HID devices, health and fitness, PoS (point-of-sales), M2M connectivity, automotive aftermarket, industrial and home automation gateways and others.

## 1.3 Block diagram

The block diagram for Bluegiga *Bluetooth* Dual Mode module BT121 is shown in below.

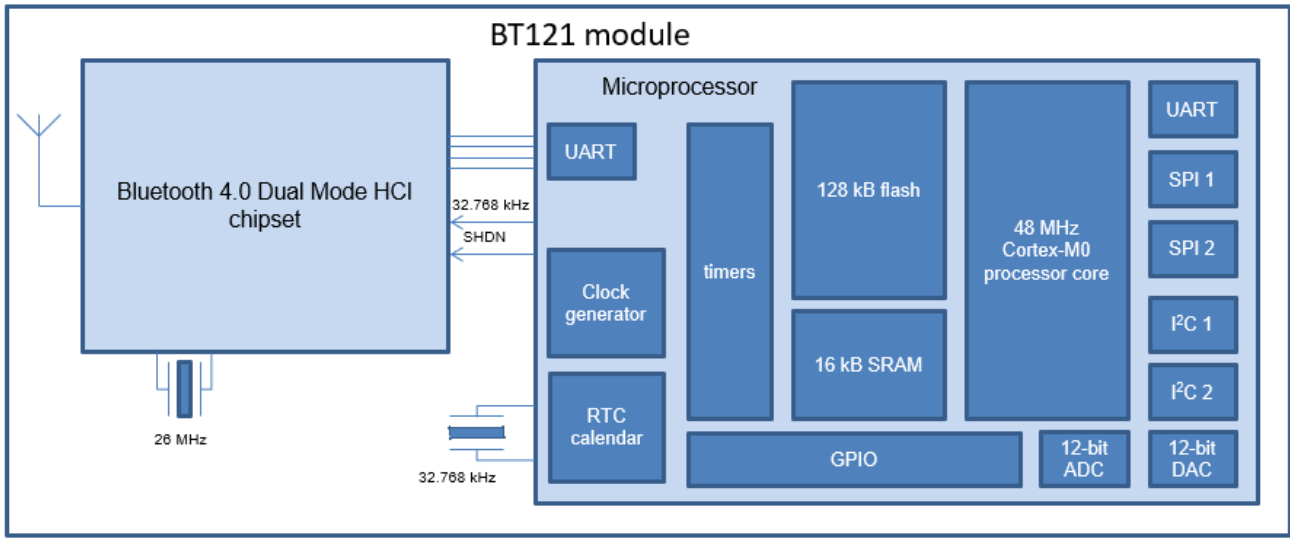

Figure 1 BT121 Bluetooth Dual Mode module block diagram

## 2 Design guidelines

Certain hardware related design guidelines should always be followed when developing applications based on the BT121 module.

### 2.1 PCB layout recommendations

- All ground pads should be connected to a ground plane.
- The antenna layout should follow the example shown in [Figure 2](#) below and avoid the designs shown as crossed over.
- BT121 requires minimal free space around the module and only the white area marked in the PCB picture series presented in [Figure 2](#) below needs to be free of copper and components.

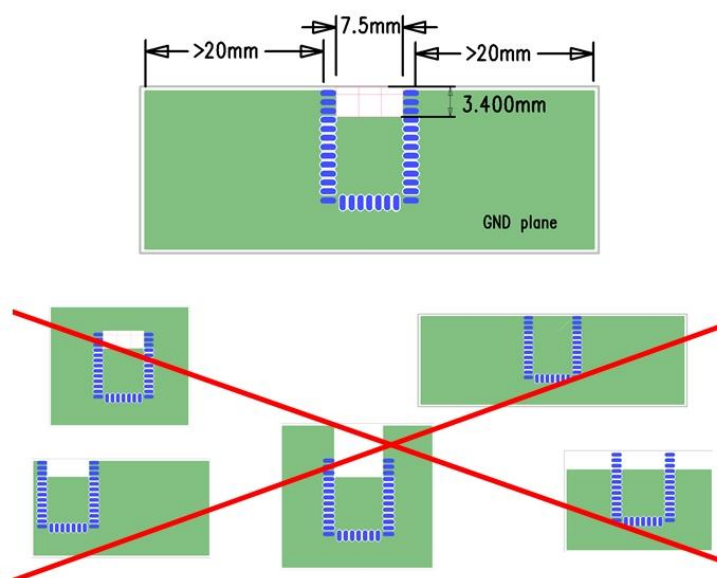

Figure 2 PCB layout recommendations for BT121 application boards

### 2.2 Power supply recommendations

The regulator used must be capable of supplying a peak current of 150 mA and the regulator must be of a type stable with ceramic capacitors.

### 2.3 Software application related options

BT121 can be used either as a stand-alone solution by using the Bluegiga BGScript™ scripting language or alternatively if the application software size or other factors require together with an external host processor by using Bluegiga BGAPI™ commands. The decision on which approach to use is most often dictated by the limits set by the internal memory of the BT121 module.

### 2.4 Firmware updating related recommendations

To enable firmware updating an external UART interface connection as shown in [Figure 3](#) on the next page is mandatory. BT121 firmware can be updated through the UART interface by holding the host MCU in reset state which typically will free the UART lines to be used by the update interface.

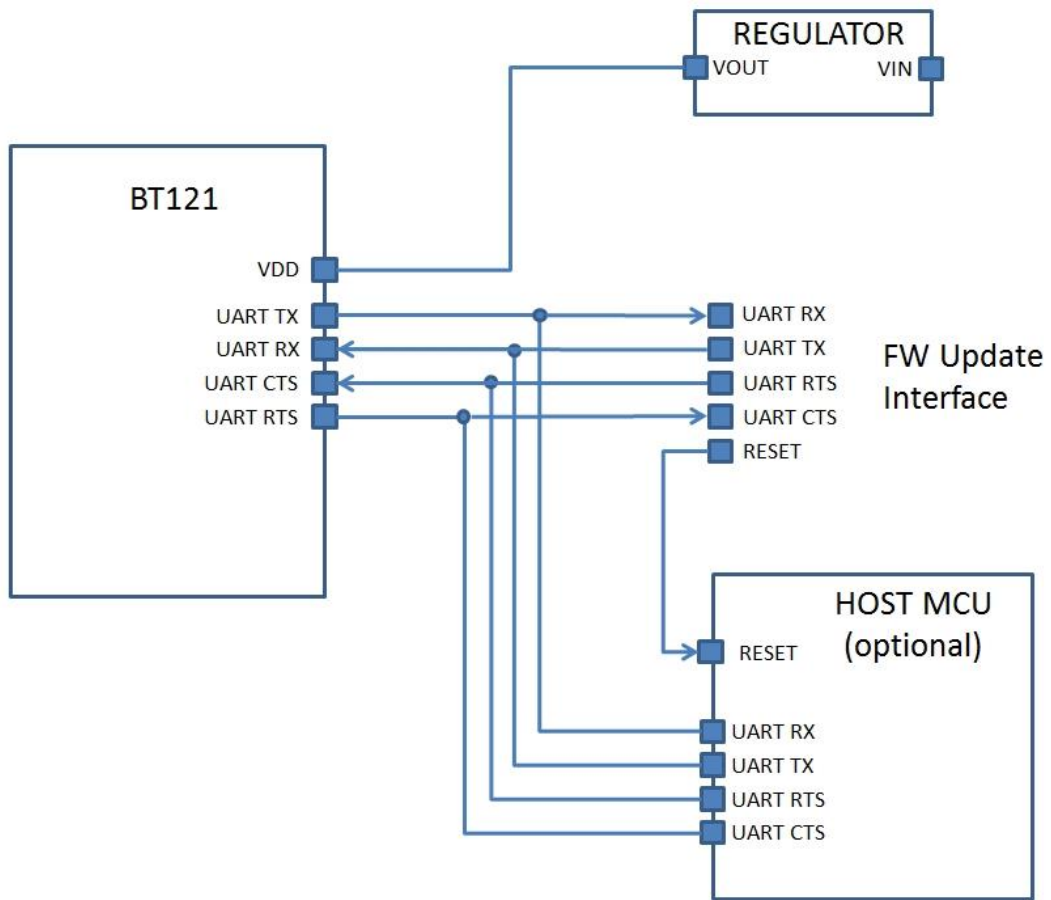

Figure 3 BT121 firmware update via UART connection example

### 3 Pin-out description

This section contains a description of the BT121 pin-out. Each pin may have one or more functions which are all listed in tables. The pin-out is shown in *Figure 4* below.

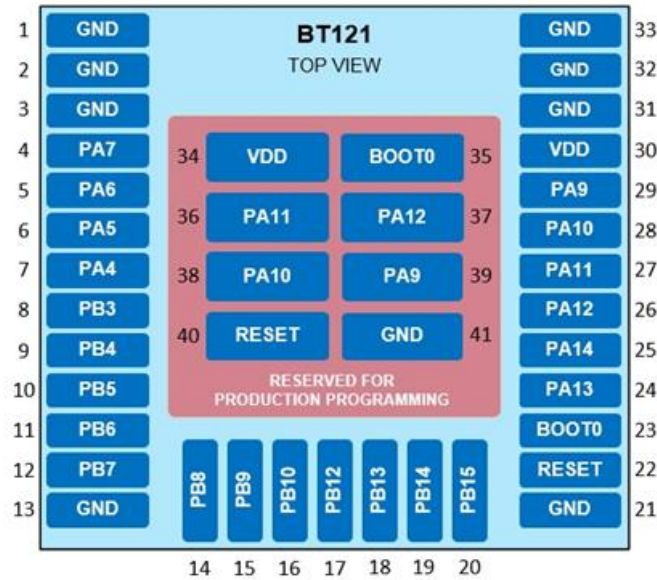

Figure 4 BT121 pin-out (top view)

#### 3.1 Power, ground, reset, RF and boot loader pins

Power supply, ground, reset signal, RF antenna input/output and boot loader related pins are listed in *Table 1* below.

Pin / Pad	Function	Description
30,34	VDD	Module power supply input pins.
1, 2, 3, 13, 21, 31, 32, 33, 41	GND	Ground pin. These are all connected together internally but they should all be individually connected directly to a solid ground plane with vias in close proximity to the pins. This requirement concerns especially the antenna connections.
22,40	RESET	Module reset signal pins. Pulling RESET low will reset the internal processor of the module. These connections have an internal pull-up and can be left floating if not needed. The RESET pin s forced low internally on power-on. External reset sources should be open drain.
23,35	BOOT0	Boot mode pin of the microcontroller internal boot loader. This connection has an internal pull-down and should be left floating or pulled low in normal operation. If the Bluegiga DFU is overwritten or disabled, pulling BOOT0 high at reset will allow DFU to be rewritten through the UART (serial port interface).

Table 1 Power, ground, reset, RF and boot loader pins

## 3.2 GPIO pins

General purpose I/O pins and their functions are listed below.

PERIPHERAL FUNCTION	GPIO NAME																						
	PA7	PA6	PA5	PA4	PB3	PB4	PB5	PB6	PB7	PB8	PB9	PB10	PB12	PB13	PB14	PB15	PA13	PA14	RTS PA12	CTS PA11	RX PA10	TX PA9	
<b>PIN NUMBER</b>	4	5	6	7	8	9	10	11	12	14	15	16	17	18	19	20	24	25	26 37	27 36	28 38	29 39	
<b>DEFAULT FUNCTION **</b>	dc	dc	dc	dc	dc	dc	dc	dc	dc	dc	dc	dc	dc	dc	dc	dc	dc	dc	dc	dc	dc	dc	
<b>5V TOLERANT</b>	N	N	N	N	Y	Y	Y	Y	Y	Y	Y	Y	Y	Y	Y	Y	Y	Y	Y	Y	Y	Y	
<b>UART ***</b>																				RTS	CTS	RX	TX
<b>SPI 1</b>	Alt.1	MOSI	MISO	SCK																			
	Alt.2				SCK	MISO	MOSI																
<b>SPI 2</b>	Alt.1											SCK			MISO	MOSI							
	Alt.2												SCK	MISO	MOSI								
<b>I<sup>2</sup>C 1</b>	Alt.1							SCL	SDA														
	Alt.2									SCL	SDA												
<b>I<sup>2</sup>C 2</b>	Alt.1																						
	Alt.2													SCL	SDA								
<b>DAC output</b>			AO2	AO1																			
<b>ADC input</b>	AIN7	AIN6	AIN5	AIN4																			
<b>Interrupt channel</b>	7	6	5	4	3	4	5	6	7	8	9	10	12	13	14	15	13	14	12	11	10	9	

Table 2 General purpose I/O pins and their functions

\*\* Default pin functions on production firmware / dc = disconnected, no need to pull up or down

\*\*\* UART can be used as a BGAPI™ host interface and DFU firmware updates

If the pins are set as GPIO rather than UART signals the DFU cannot work, see UART (Section 5.2) and recovery mode (Section 4.4)

**GPIO pins 36, 37, 38 and 39**  
Reserved for production testing  
Must be left unconnected



I<sup>2</sup>C 2 can be used only Alt. 2 configuration

## 4 Power control

### 4.1 Power supply requirements

BT121 is powered by a single power supply input (VDD). Nominal input voltage is 3.3 VDC and input voltage range 2.2 V to 3.6 V. If the module's internal ADC and/or DAC functions are used minimum allowed power supply voltage is 2.4V.

The VDD supply should be capable of supplying a peak current of at least 150 mA even though the average current consumption of BT121 will be much less than that. External high frequency bypass capacitors are not needed because the module contains the necessary power supply filtering capacitors.

Careful design of the layout and proper component selection are necessary to prevent switching noise from appearing on the supply line. Such disturbances can be caused by on-board charge pump converters (e.g. RS232 level shifters). Charge pump based converters tend to have strong switching spikes which are difficult to filter out and may degrade RF performance. A ferrite chip can be added in series with the supply line close to the module supply pin to reduce RF interference through the supply line.

There is a total of about 1.5  $\mu$ F of ceramic capacitors on the VDD line inside the module. When using low drop linear regulators to generate a regulated supply voltage for the VDD line, the stability of the regulator with the low ESR provided by these capacitors should be checked. Many linear regulators and some switched mode ones too are not stable when used with ceramic output capacitors. The regulator datasheets usually have recommendations for output capacitor ESR range or they contain a stability curve to help select components properly. A regulator designated as "stable with ceramic capacitors" is recommended.

### 4.2 Power saving functionality

BT121 contains two configurable power saving modes. The internal RTC (Real Time Clock) is usually kept always running to avoid the long wake-up time associated with the internal 32 kHz crystal oscillator. The RTC is always available to wake up the module.

#### 4.2.1 Power mode 1

Power mode 1 is a shallow sleep state with all clocks and peripherals running but with the processor core stopped. It is used automatically and has no impact on module performance and does not require special considerations in user applications. See [Table 3](#) on next page.

#### 4.2.2 Power mode 2

Power mode 2 is a deep sleep state, in which most peripheral devices and system clocks are powered down. The UART interfaces cannot operate without clocks, and instant communications with the host are not possible. A separate wake-up pin can be used to wake up the module, which will stay on as long as the wakeup pin is held high. GPIO interrupts, activity on the radio and RTC interrupts can also cause a wake-up event. There is a short wake-up delay due to the time required for the internal clocks to stabilize and because of this the module processor is not instantly ready to receive data. See [Table 3](#) on next page.

#### 4.2.3 Wake-up pin functionality

This feature can be used to prevent to *Bluetooth* module from entering a sleep mode or alternatively can be used to wake it up from a sleep mode. If the sleep modes have been enabled in the hardware configuration file (see *Bluetooth Dual Mode Configuration Guide*) and use UART to communicate with the module, then this feature must be enabled and the wake-up pin must be asserted before sending any data or BGAPI commands to the module, and also kept asserted until the last byte has been transferred into the module over the UART.

The wake-up pin functionality can only be assigned to a single GPIO, but it is still possible to assign normal GPIO interrupts to other pins. The difference between the wake-up pin and normal GPIO interrupts is that the wake-up pin will not only generate the interrupt which wakes the module, but will also keep the module awake as long as it is held in the asserted state. Normal GPIO interrupts can wake the module from any state but after the interrupt event handler completes the module will return to sleep.

There is always a delay before the module wakes up. It is possible to measure the wake-up time by measuring when flow control starts to work. Data should not be sent before the module has waken up to prevent data loss. Monitor the RTS/CTS signal to detect when the module has waken up. There is no special command separately to wake up the module.

Power mode	CPU clocks	CPU core	Radio	Wakeup delay	UART	Current consumption *
Active	ON	Running	On	-	Active	10 - 20 mA
Power mode 1	ON	Sleep	On	< 1µs	Active	4 - 10 mA
Power mode 2	OFF	Stopped	On	< 7 µs	Off	50 - 100 µA

**Table 3 Power modes with corresponding wakeup delays and current consumption**

\* Current consumption with radio inactive

The logic flow of the power saving modes in relation to each other is shown in *Figure 5* below. It is to be noted that the processor will not lose RAM contents regardless of the power mode used.

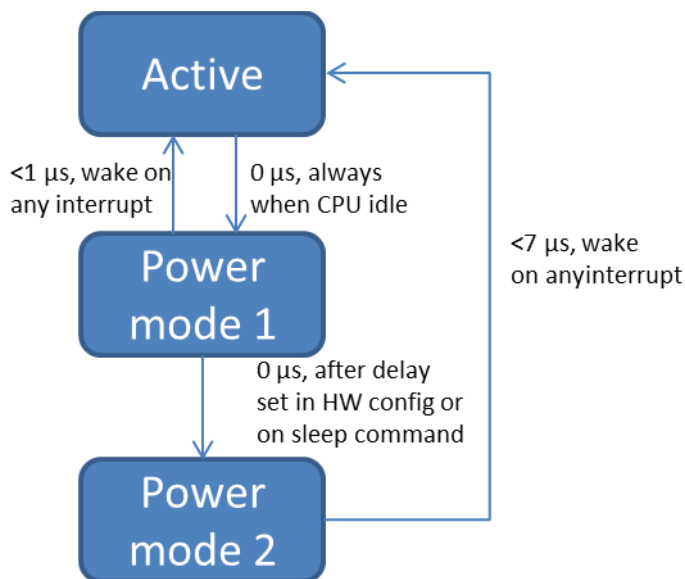

**Figure 5 Power modes in relation to each other and to active mode**

### 4.3 Reset

BT121 can be reset by several methods: by pulling the RESET pin low, by the internal system power-up reset functionality or by the internal watchdog timer. The RESET pin is internally connected to a pull-up resistor with a resistance of approximately 40 kohm. The RESET pin should be connected to a push-button, header or test point to enable the use of the system recovery mode.

On an internal reset, the RESET pin will be briefly pulled low internally. It is recommended that an external reset source is of an open drain type.

## 4.4 Recovery mode

Pulling the BOOT0 pin high at reset sets the BT121 module's internal microcontroller into a recovery mode, which allows the Bluegiga DFU to be rewritten to the module using the BGTOOL software. The BOOT0 pin should be connected to a header or test point to enable DFU recovery. The pin is internally connected to a 10 kohm pull-down resistor.

## 4.5 Clock signals

BT121 generates all the required clock signals internally. The clocks used by the internal microcontroller and external peripherals are synchronized to an internal 32.768 kHz crystal connected to the internal RTC. The micro power RTC is always kept running when the module is supplied with power. It will take approximately two seconds for the RTC oscillator to stabilize after power is connected. To avoid this delay it is recommended that the power supply feed to the BT121 is not switched off but instead the module can be set into the lowest power mode providing the smallest current consumption.

## 5 Interfaces

### 5.1 GPIO

BT121 contains a number of pins which can be configured to operate as general purpose digital I/O's, analog inputs or outputs or to be used in combination with various built-in functions. The module contains I2C, SPI, UART, touch pad sensing and various timer functions. Most of the pins are 5V tolerant. All GPIO pins can drive currents of up to +/- 8 mA (up to 20mA with relaxed voltage specifications).

#### 5.1.1 GPIO interrupts

Any GPIO signal can be assigned an interrupt function. However, the module microcontroller has a limited number of interrupt channels available for GPIO's. The microcontroller has two separate GPIO ports, with the external signals divided between the two. An interrupt can be assigned to a specific port signal number from either port, but not for the same number on both ports simultaneously. The principle of GPIO interrupt multiplexing on the Bluegiga *Bluetooth* Dual Mode module BT121 is shown in [Figure 6](#) below.

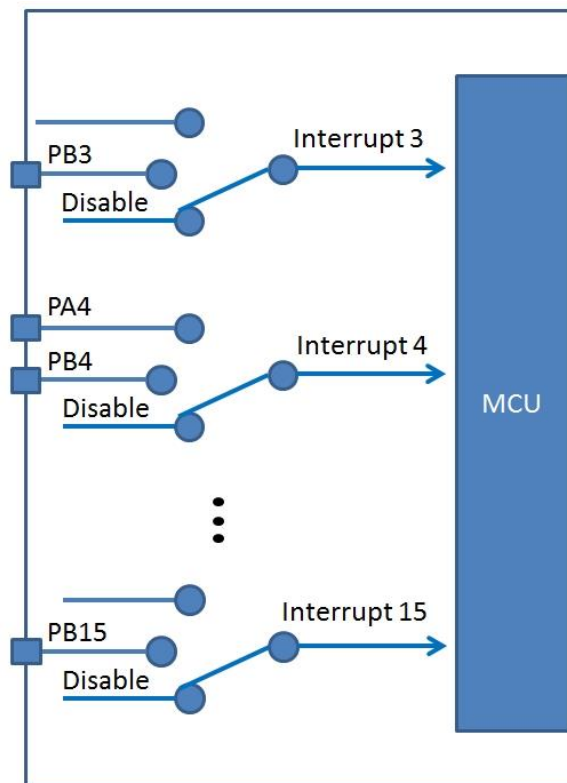

Figure 6 GPIO interrupt multiplexing scheme

## 5.2 UART

There is one UART port available on the BT121. By default, it is used for BGAPI™ host interface but with BGScript™ it can be used as an application UART. The UART supports all standard baud rates up to 4 Mbps. RTS/CTS handshake scheme is supported and recommended for every application for reliable data transfer.

## 5.3 I<sup>2</sup>C

BT121 has up to two I<sup>2</sup>C ports available. Both support standard mode up to 100 kbps, fast modes up to 400 kbps and Fast Mode Plus with improved drive capability and clock stretching up to 1 Mbps.

## 5.4 SPI

BT121 has up to two SPI ports available. Both can be configured for frame sizes from 4 to 16 bits and clock frequencies up to 18 MHz. Both ports provide internal CRC calculation. Software-controlled GPIO's should be used as slave select signals.

## 5.5 ADC

BT121 contains a 4-channel 12-bit ADC with multiple external input sources as well as an internal battery measurement and temperature measurement possibility. ADC input voltage range is 0 to VDD.

### 5.5.1 Accessory functions of the ADC

In addition to the external ADC inputs an internal temperature sensor or internal supply voltage divider can be selected as the input to ADC.



Power supply range when using internal ADC functions is 2.4 to 3.6 VDC.

## 5.6 DAC

BT121 contains a 2-channel 12-bit DAC, with two independent outputs. DAC output voltage range is 0 to VDD.



Power supply range when using internal DAC functions is 2.4 to 3.6 VDC.

## 5.7 Real-time clock

BT121 contains a real-time clock (RTC) with full calendar support and sub-second resolution. The RTC can be used for periodic or specifically programmed wakeups. The RTC is clocked by an internal crystal oscillator which is always on as long as power is supplied to the module.

## 5.8 Microcontroller programming interface

The preferred method of programming the BT121 is by using the Bluegiga DFU through the UART host interface. A problem may occur if the DFU is disabled by disabling the UART or if the DFU is overwritten accidentally. Then the DFU would need to be re-uploaded.

The two methods of DFU uploading are through the SWD interface (PA13 = SWDIO and PA14 = SWCKLK) using an ARM serial debug adapter, or by forcing the BOOT0 signal high and by resetting the module to make it boot into a recovery mode. Then the BGTool software can be used to recover the DFU through the UART interface.

## 6 Antenna

The internal chip antenna on the BT121 uses the application board ground plane as part of the antenna, and requires at least 20 mm of ground plane on both sides of the module to radiate with optimal efficiency. BT121 must be placed on the application board edge, preferably roughly in the middle of the board edge. The ground plane can be internal to the application PCB, allowing components to be placed on both sides of the module and on both sides of the application board. The module ground pads in the antenna end should be connected to the main ground plane layer with vias in immediate proximity of the pins. Thermal reliefs on the ground pins have a negligible effect on antenna performance. Typical antenna matching curves are shown in [Figure 7](#) below.

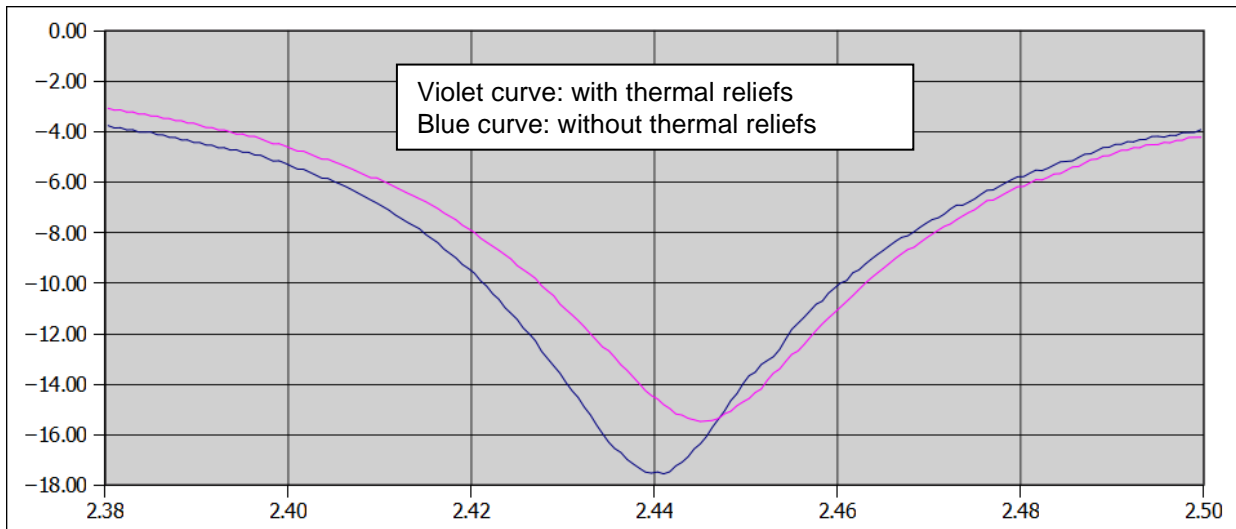

**Figure 7 Typical antenna matching**

The antenna used on the BT121 is quite robust with regard to adverse effects of close-by metallic materials. The PCB thickness will not affect the antenna operation significantly. The application board can be installed with the PCB bottom side and the antenna edge directly against a plastic casing without adverse effects. On the module top side, there should be at least 3 mm of clearance to the nearest object.

The antenna requires a 7.5 x 3.4 mm sized copper clearance in all layers, with no components or traces on the opposite side of the PCB from the antenna. Sufficient metal clearance is mandatory because the antenna will not function at all without a sufficient opening in the ground plane.

Any metal in close proximity of the antenna will prevent the antenna from radiating freely. It is recommended not to place any metal or other conductive objects closer than 10 mm to the antenna except in the directions of the application board ground planes.

A board cutout is not required for the antenna. In fact, a cutout would cause the antenna to be detuned which in turn will degrade range significantly. The module is also not to be placed in a cut-out recess on the board edge or in the middle of the board which has a central cutout.

On the following pages are examples on how plastic or metal sheets in several different orientations and distances to the antenna effect antenna matching.

### 6.1 Effect on antenna matching of a plastic sheet placed near the antenna

As an example on how a plastic sheet placed in the vicinity of the module and/or antenna effect the antenna matching we can examine [Figure 8](#) below.



**Blue curve**  
Plastic sheet under antenna touching PCB

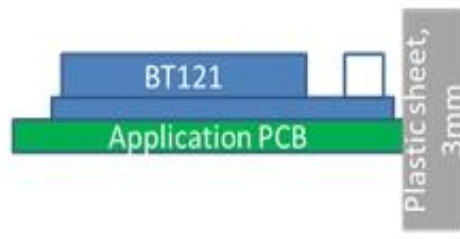

**Violet curve**  
Plastic sheet against antenna at module end

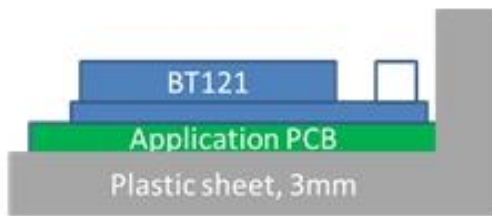

**Yellow curve**  
Plastic sheets under antenna touching PCB  
and against antenna at module end

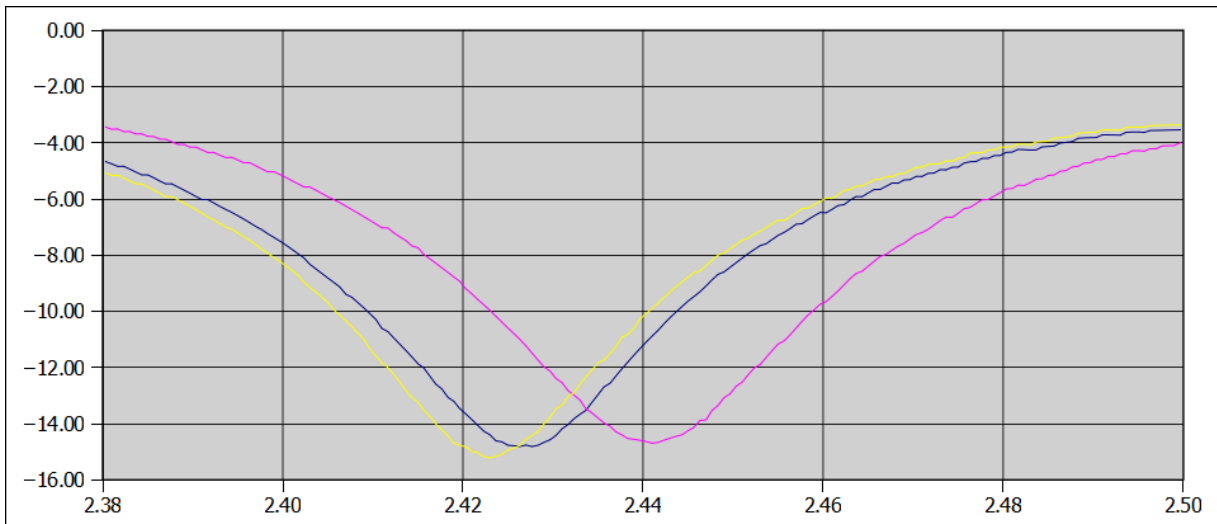

**Figure 8 Proximity effect of a 3 mm plastic sheet on antenna matching with different placements**

## 6.2 Effect on antenna matching of a metal sheet placed under the antenna

As an example on how a metal sheet placed in the vicinity of the module and/or antenna effect the antenna matching we can examine [Figure 9](#) below.

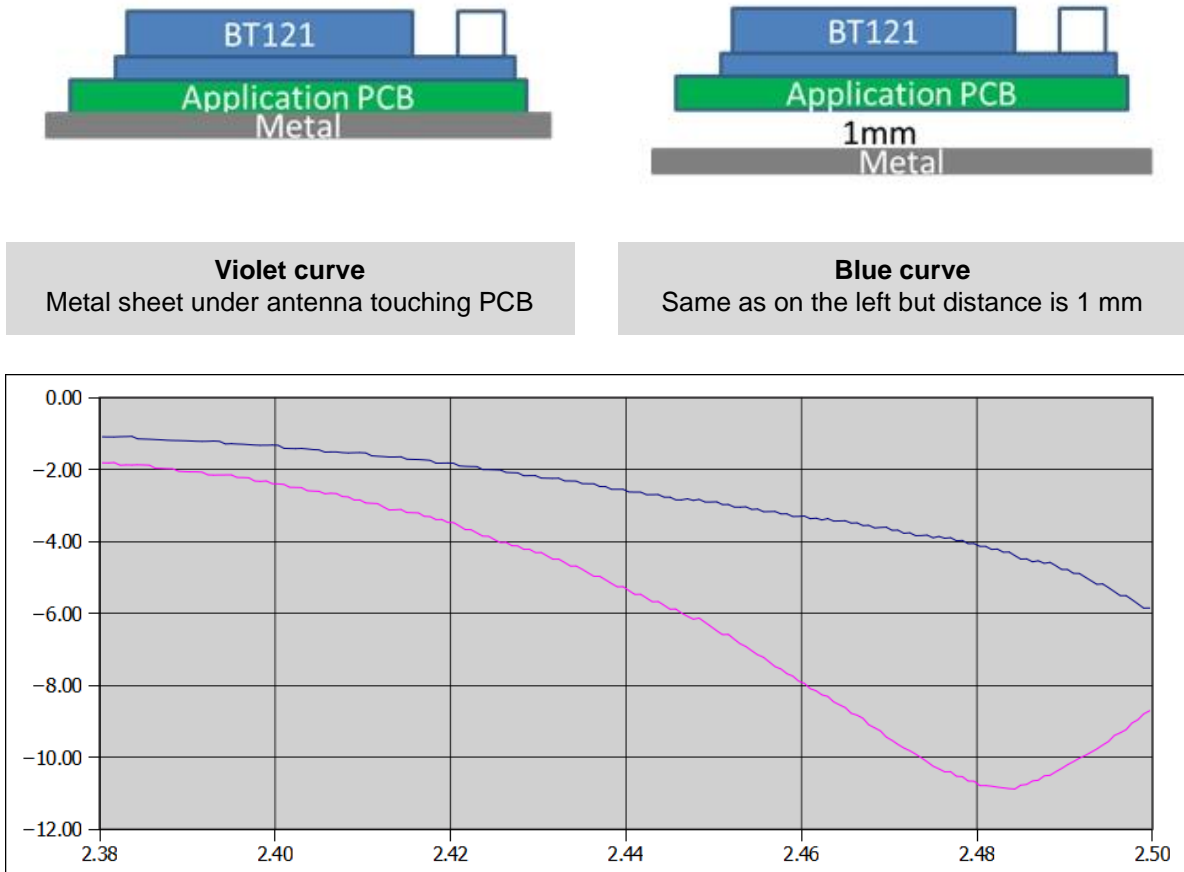

**Figure 9** Effect of a metal sheet placed under the antenna on antenna matching

### 6.3 Effect on antenna matching of a metal sheet placed against the end of the module

As an example on how a metal sheet placed in the vicinity of the module and/or antenna effect the antenna matching we can examine [Figure 10](#) below.

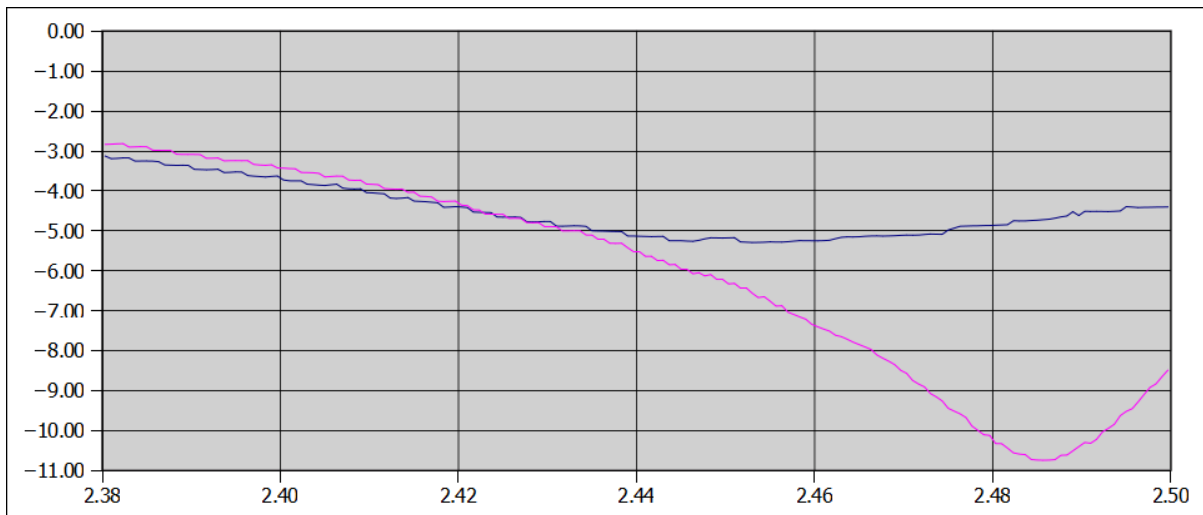
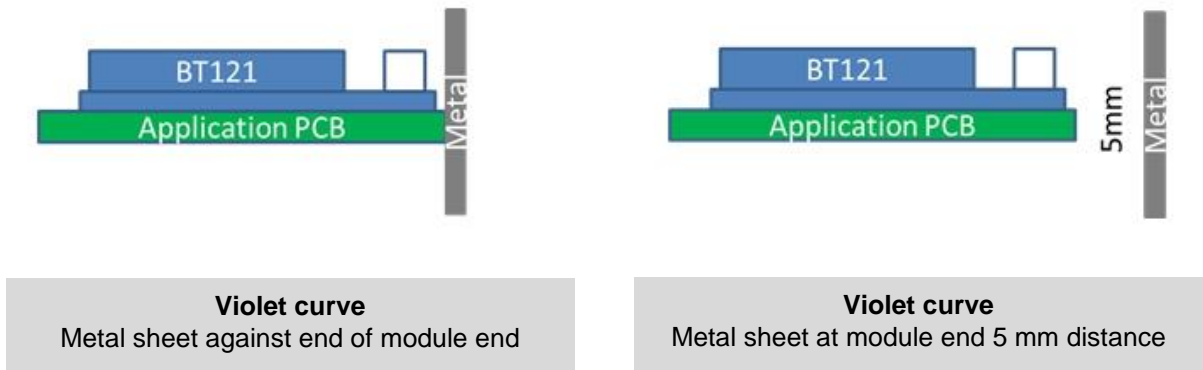
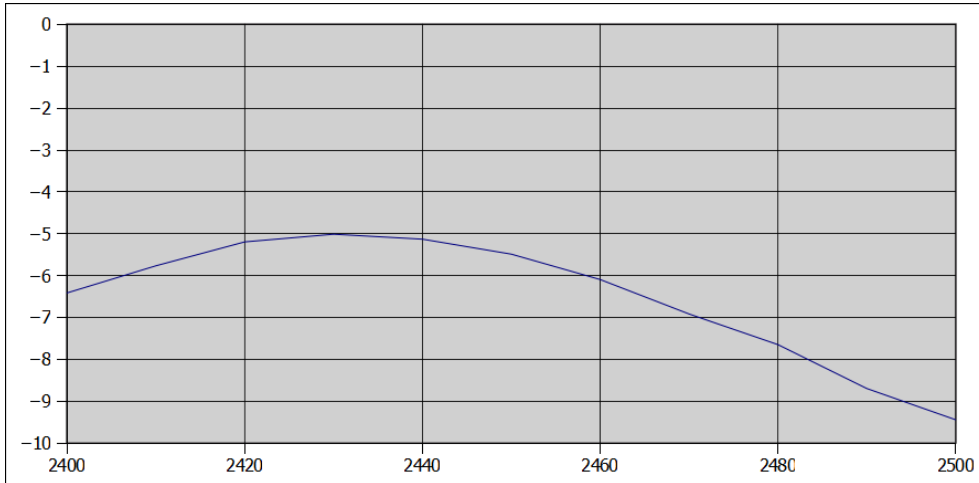

Figure 10 Effect of a metal sheet placed under the antenna on antenna matching

## 6.4 Measured antenna efficiency

The measured antenna efficiency as a function of frequency is shown in [Figure 11](#) below.



**Figure 11** Antenna efficiency related to frequency

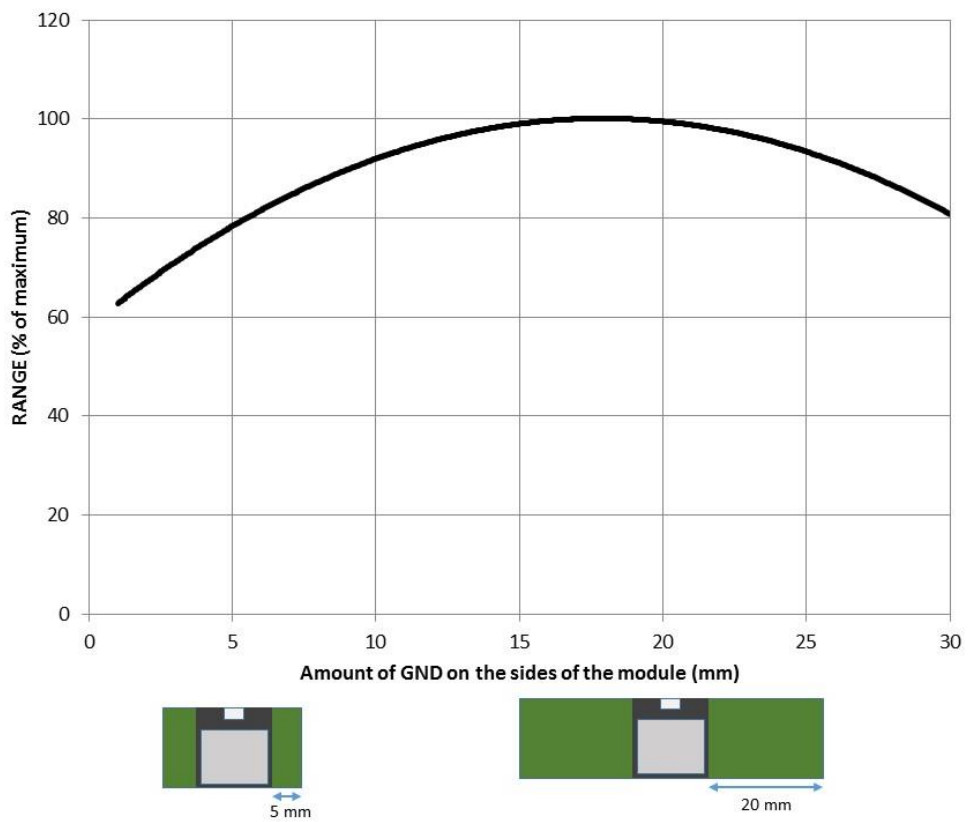

**Figure 12** Impact of the size of GND plane to the range of BT121

## 6.5 Measured 2D radiation patterns

Typical radiation patterns of the BT121 module on the DKBT carrier board as 2D plots are shown below in [Figure 13](#) (view from module side), [Figure 14](#) (view from antenna end) and on the following page in [Figure 15](#) (view from above module).

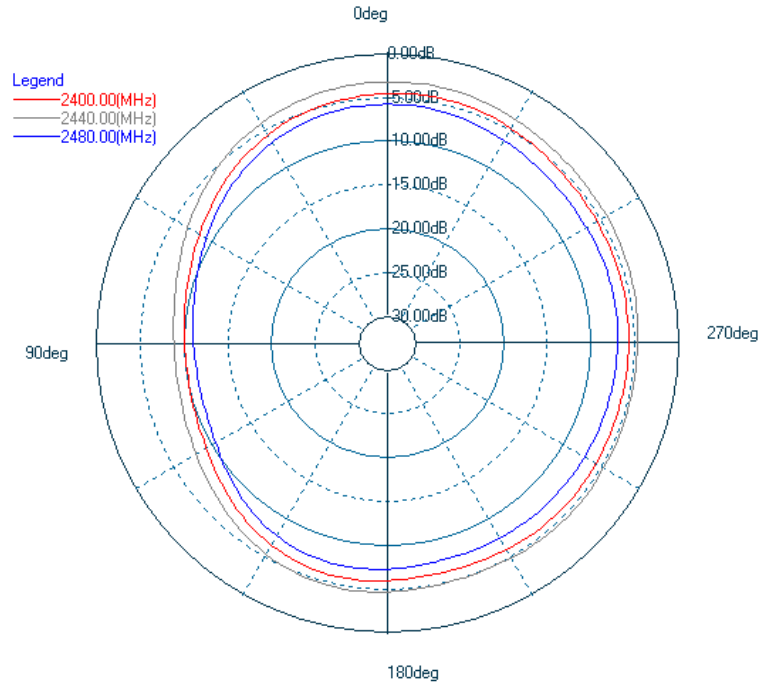

**Figure 13** Typical 2D radiation pattern for BT121 with view from module side

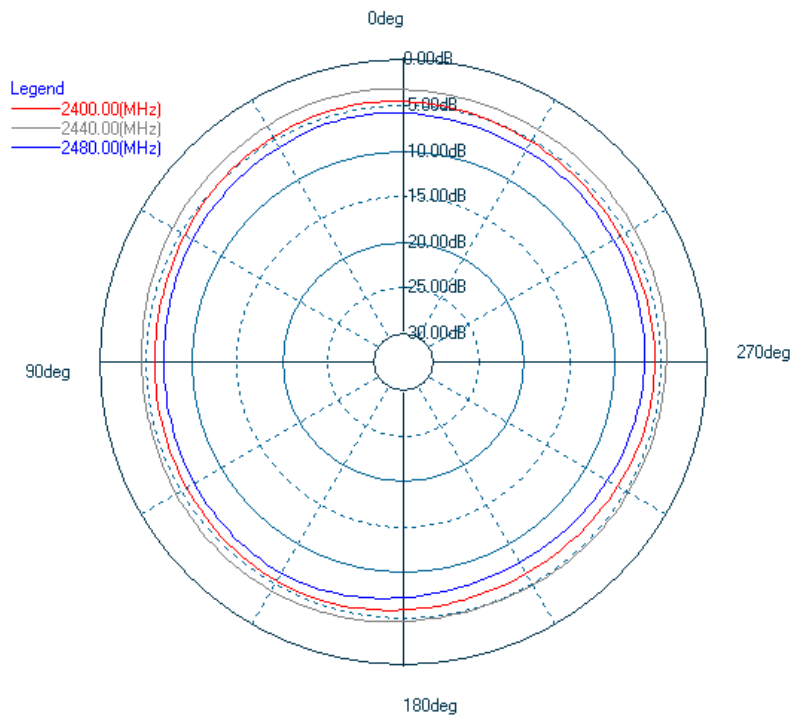

**Figure 14** Typical 2D radiation pattern for BT121 with view from antenna end side

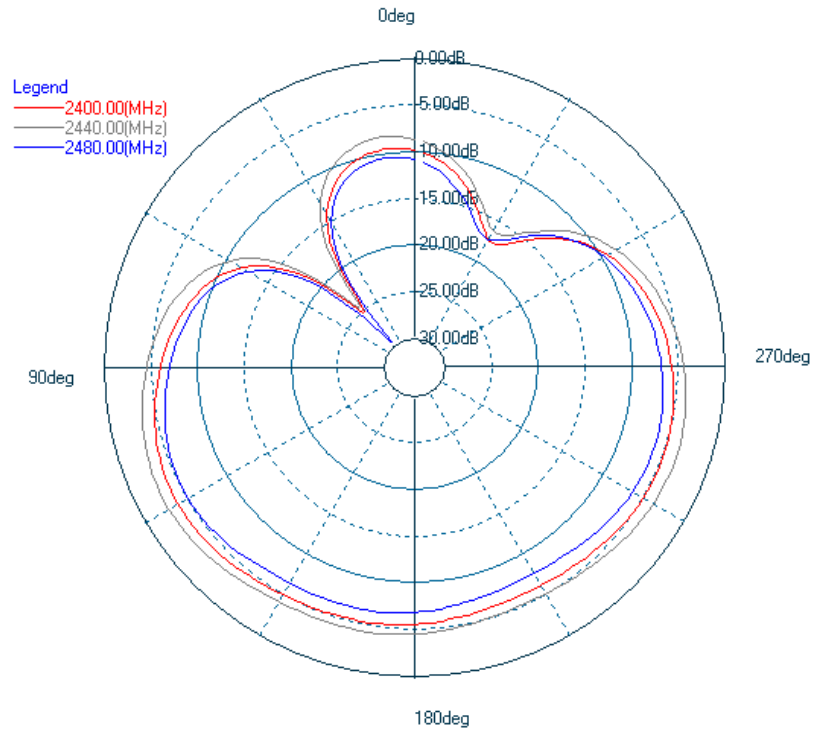

Figure 15 Typical 2D radiation pattern for BT121 with view from above module

## 6.6 Measured 3D radiation patterns

Typical radiation patterns of the BT121 module on the DKBT carrier board as 3D plots are shown below. [Figure 16](#) represents a radiation pattern from module end side opposite to antenna and [Figure 17](#) from above the module.

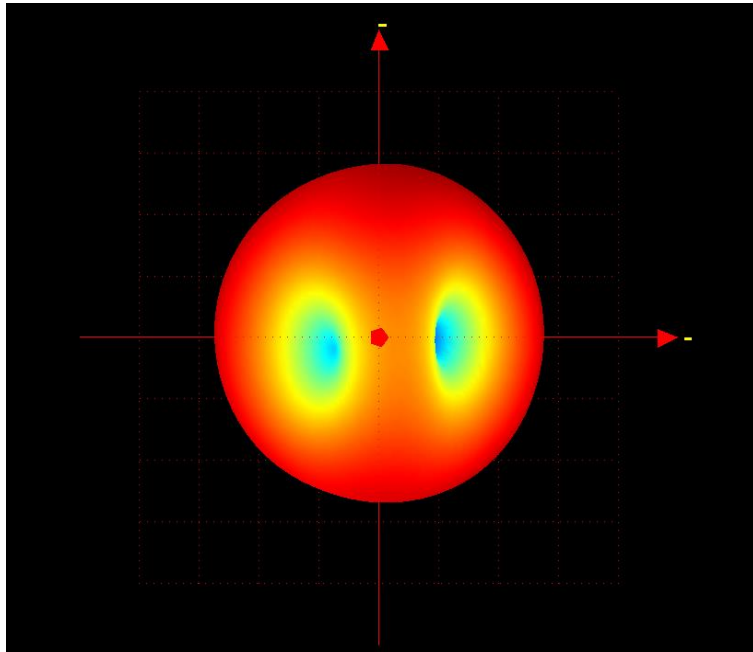

Figure 16 Typical 3D radiation pattern for BT121 with view from module end opposite to antenna

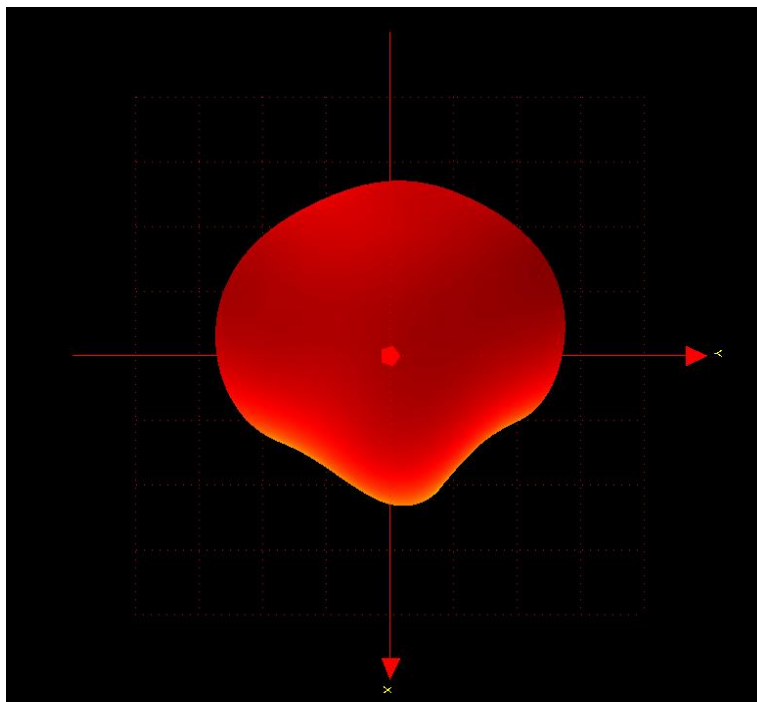

Figure 17 Typical 3D radiation pattern for BT121 with view from above the module

## 7 Bluetooth Stack Software

Bluegiga's *Bluetooth* Dual Mode Software is a complete *Bluetooth* Dual Mode software stack for BT121 *Bluetooth* Dual Mode module. The software implements a full *Bluetooth* BR/EDR and LE compatible *Bluetooth* Stack and L2CAP, RFCOMM, SMP and ATT protocols as well as *Bluetooth* SPP, HID, Apple iAP2, GATT over BT profiles and any GATT based *Bluetooth* LE profile.

The *Bluetooth* Dual Mode Software also is supported by a complete SDK for developing *Bluetooth* Dual Mode applications using either an external host or BGAPI™ serial protocol over UART or fully standalone applications based on a simple scripting language called BGScript™.

Several profiles and software project examples are offered as part of the *Bluetooth* Dual Mode SDK to help expedite the development of *Bluetooth* Dual Mode compatible end-user products.

The main parts of the Bluegiga *Bluetooth* Dual Mode software stack are shown below.

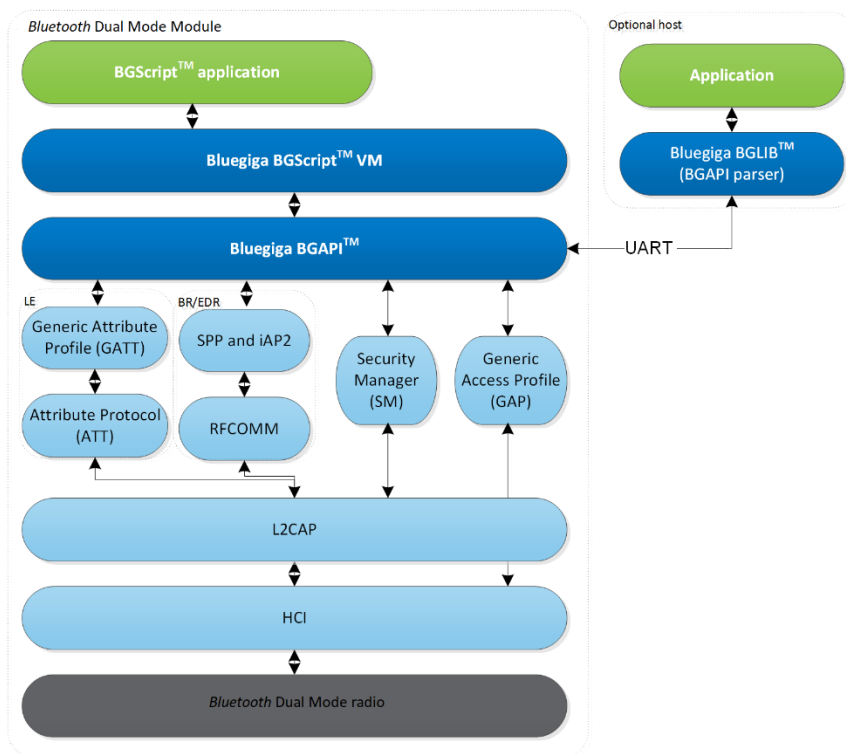

Figure 18 Bluegiga Bluetooth Dual Mode software stack



To learn more about the Bluetooth Dual Mode software stack, the SDK and the APIs please read ***Bluetooth Dual Mode Software Getting Started Guide***.

## 8 Host interface

### 8.1 UART

For applications where an external host such as MCU is used BT121 can be controlled over the UART interface using the BGAPI™ serial protocol.

For reliable communications can data transfer the hardware flow control RTS/CTS signals must be used in the UART interface.

It is also recommended that the accuracy of the clock of the controlling host should be 1% or better for the UART signaling to work reliably with speeds exceeding 115200 kbps (maximum baud rate is 4 Mbps).

Default UART settings are listed below:

Parameter	Default setting
UART baud rate	115200
RTS/CTS flow control	Enabled
Data bits	8
Parity	None
Stop bits	1

**Table 4 BT121 UART interface default settings**

## 9 Connection examples

The following sections show how to connect a Bluegiga *Bluetooth* Dual Mode module with various external devices using the UART, SPI and I<sup>2</sup>C interface.

### 9.1 Connecting an external host using the UART interface

The connection to an external host is done using the UART interface of the module. This interface is also used for module reprogramming using the DFU method and thus an optional connector should be provided on the application PCB to allow reprogramming if needed. A typical solution then is to hold the host in reset state which will keep the UART pins of the host floating, allowing the interface to be used for programming the module by using e.g. a PC and suitable software. See [Figure 19](#).

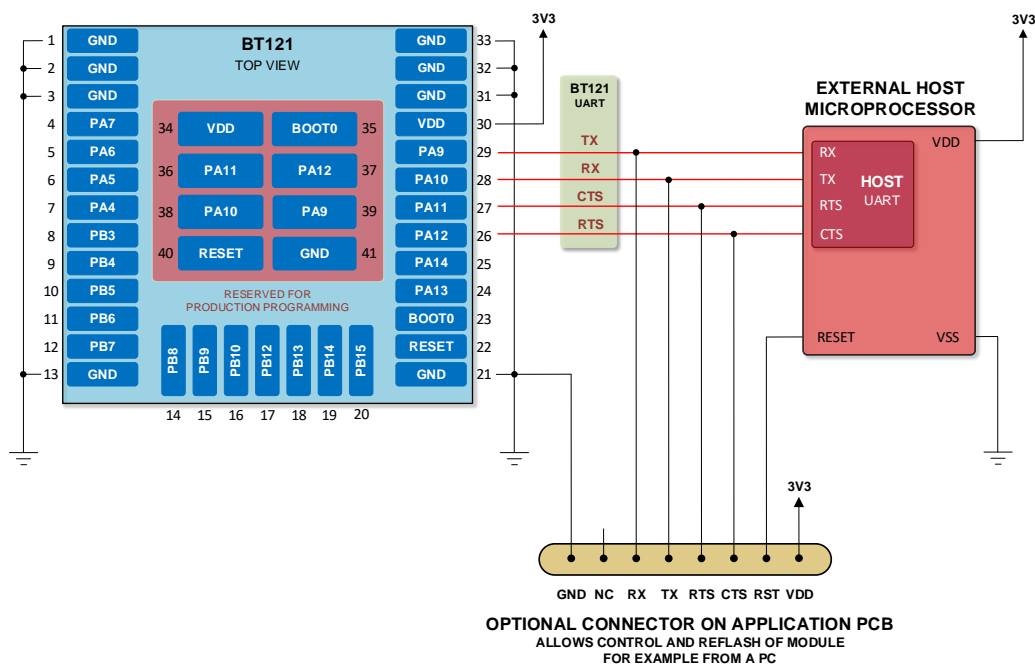

Figure 19 Connecting an external host with BT121 using UART

## 9.2 Connecting an external device using SPI interface

Bluegiga *Bluetooth* Dual Mode module BT121 contains two physical SPI peripherals (SPI 1 and SPI2) each with alternative configurations (Alt 1 and Alt 2). All of the four optional configurations can be used to connect different types of peripheral devices to the module. Pin configurations for the four SPI interface options are listed in [Table 2](#). An example of this type of interfacing is shown in [Figure 20](#) below. In the example below a generic EEPROM memory peripheral chip is connected to the BT121 using the **SPI 1 Alt 2** option.

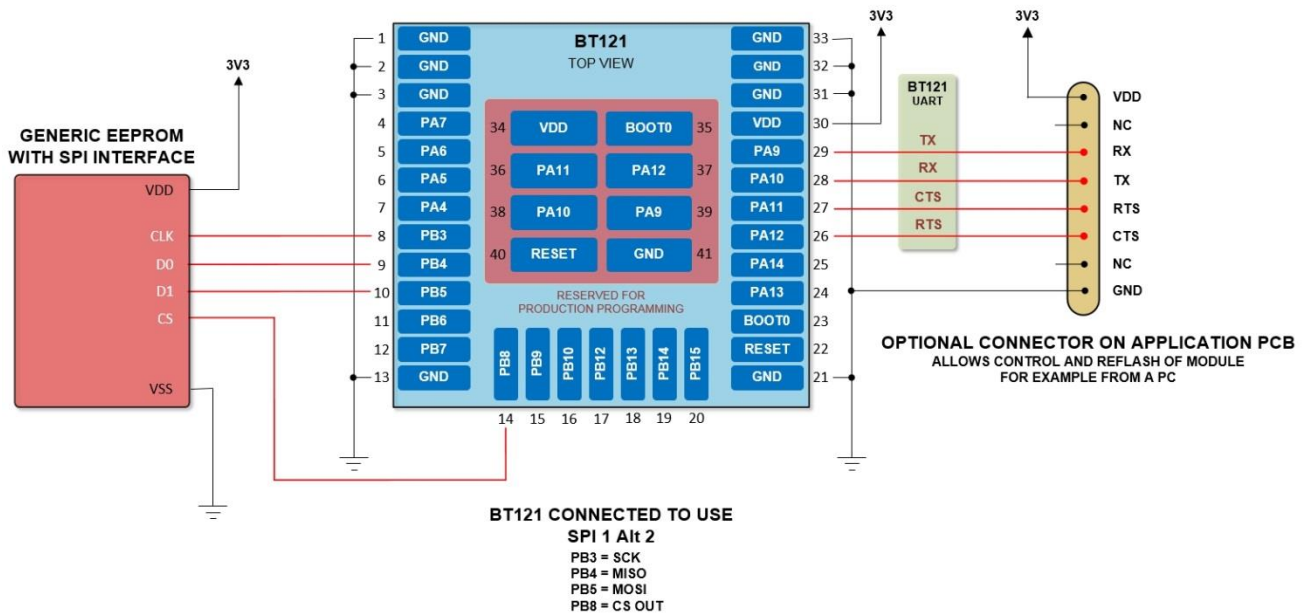

Figure 20 Connecting an external device with BT121 using SPI interface

### 9.3 Connecting an external device using I<sup>2</sup>C interface

Bluegiga *Bluetooth* Dual Mode module BT121 contains two physical I<sup>2</sup>C peripherals (I<sup>2</sup>C 1 and I<sup>2</sup>C 2). I<sup>2</sup>C 1 has two alternatives (Alt 1 and Alt 2) and I<sup>2</sup>C 2 one alternative (Alt 2). All of the three optional configurations can be used to connect different types of peripheral devices with the module. Pin configurations for the three I<sup>2</sup>C interface options are listed in [Table 2](#). An example of this type of interfacing is shown in [Figure 21](#) below. Note the pull-up resistors on the SDA and SCL lines. The example shows the address/chip select lines of the generic peripherals hardwired to VDD but in practice all or some of them would be wired to GPIO pins of the BT121 configured to work as chip select or address lines controlled by the application hardware. In the example below a generic sensor chip is connected to the BT121 using the I<sup>2</sup>C 1 Alt 1 option.

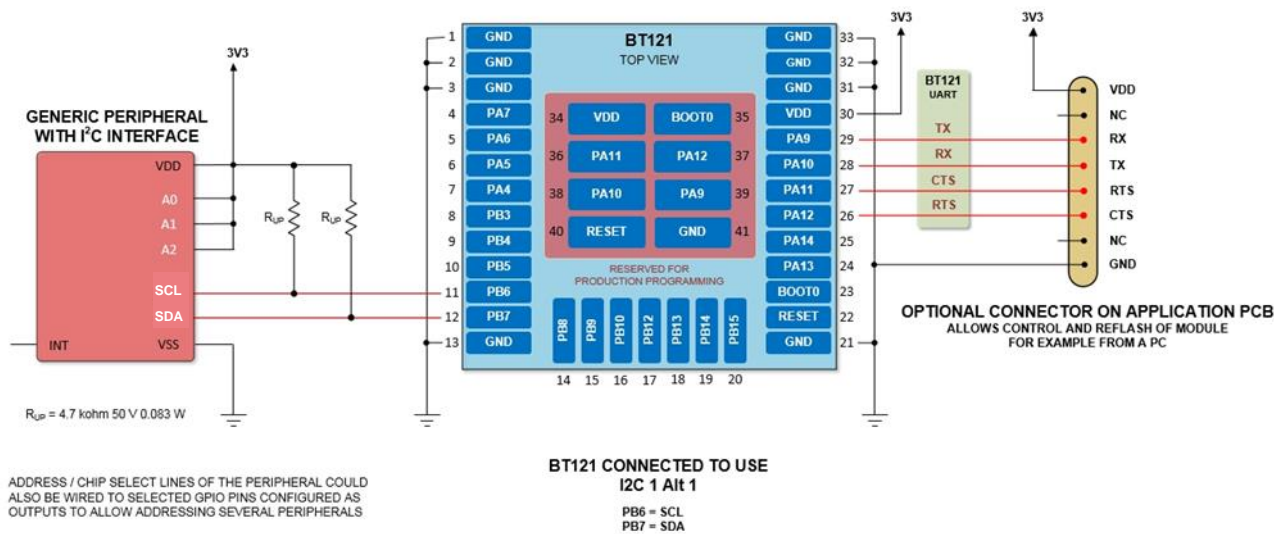

Figure 21 Connecting to an I2C peripheral

## 10 Electrical characteristics

### 10.1 Absolute maximum ratings

Parameter	Min	Max	Unit
Storage temperature	-40	85	°C
VDD	-0.3	3.6	V
5V tolerant GPIO voltages	-0.3	5.5	V
Other terminal voltages	-0.3	VDD+0.3	V
Output current sourced or sunk by any GPIO pad		25	mA
Current on all GPIO pads combined		120	mA

**Table 5 Absolute maximum ratings**

### 10.2 Recommended operating conditions

Rating	Min	Max	Unit
Operating temperature range	-40	85	°C
VDD	2.2	3.6	V
VDD (when operating ADC or DAC)	2.4	3.6	V

**Table 6 Recommend operating conditions**

## 10.3 Logic signal characteristics

### 10.3.1 Digital I/O

Digital I/O pins	Min	Typ	Max	Unit
<b>Input voltage levels</b>				
V <sub>IL</sub> input logic level low 1.7V ≤ VDD ≤ 3.6V	-0.3	-	0.3VDD	V
V <sub>IH</sub> input logic level high 1.7V ≤ VDD ≤ 3.6V	0.7 VDD	-	VDD + 0.3	V
<b>Output voltage levels</b>				
V <sub>OL</sub> output logic level low, Vdd = 3.6 V, I <sub>ol</sub> = 7 mA	-	-	0.4	V
V <sub>OH</sub> output logic level high Vdd = 3.6 V, I <sub>oh</sub> = -12 mA	VDD - 0.4	-	VDD	V

**Table 7 Digital I/O pin electrical characteristics**

### 10.3.2 Reset

Power-on Reset	Min	Typ	Max	Unit
Power on reset threshold (rising edge)	1.84	1.92	2.00	V
Power on reset threshold (falling edge)	1.80	1.88	1.96	V
RESET signal pulse width (pulled low)	1.5	-	-	ms

**Table 8 Reset pin characteristics**

### 10.3.3 ADC

Power-on Reset	Min	Typ	Max	Unit
ADC input impedance	-	-	50	kohm
ADC input voltage range	0	-	VDD	V
ADC differential nonlinearity error	-	0.7	1.3	LSB
ADC integral nonlinearity error	-	0.8	1.7	LSB
ADC offset error	-	1	2.8	LSB
ADC gain error	-	0.5	3	LSB

**Table 9 ADC pin characteristics**

### 10.3.4 DAC

Power-on Reset	Min	Typ	Max	Unit
DAC output load impedance	5	-	-	kohm
DAC output voltage range	0.2	-	VDD - 0.2	V
DAC differential nonlinearity	-	-	2	LSB
DAC integral nonlinearity	-	-	4	LSB
DAC offset error	-	-	12	LSB
DAC gain error	-	-	0.5	%

**Table 10 DAC pin characteristics**

## 10.4 Power consumption

Operation state	Current	Unit	Description
CPU active	14	mA	CPU active RF idle
Power state 1 - RF idle	6.7	mA	CPU idle RF idle
Power state 2 - RF idle	81	µA	CPU sleep RF idle
Reset state	6-13	mA	Reset-signal held low
Continuous transmission - BDR	92	mA	+12dBm, CPU active
Continuous transmission - EDR	85	mA	+12dBm, CPU active

**Table 11 Typical power consumption of different operating states**

Operation state	Current	Unit	Description
Idle, not visible, not connectable	6.0	mA	
Idle, visible, connectable	6.7	mA	
Inquiry	38.7	mA	
Connected, no data	11.1	mA	
Connected, no data, sniff 1s	6.6	mA	
Connected, continuous data	15.8	mA	115.2kbps over BGAPI
Connected, continuous data, 1s sniff	7.2	mA	115.2kbps over BGAPI

**Table 12 Typical power consumption, BR/EDR Bluetooth (Master mode, CPU sleep disabled)**

Operation state	Current	Unit	Description
Idle, visible, connectable	800	µA	
Inquiry	33	mA	
Connected, no data	5.1	mA	

Connected, no data, sniff 1s	520	μA	
Connected, continuous data	15.8	mA	115kbps over BGAPI*
Connected, continuous data, sniff 1s	7.2	mA	115kbps over BGAPI*

**Table 13 Typical power consumption, BR/EDR Bluetooth (Master mode, CPU sleep enabled)**

\*sleep controlled by wakeup pin, in the constant UART data streaming test the CPU is not allowed to enter sleep mode

Operation state	Current	Unit	Description
Advertising, not connectable	1.4	mA	108ms
Advertising, connectable	1.7	mA	108ms
Advertising, not connectable	242	μA	1000ms
Advertising, connectable	280	μA	1000ms

**Table 14 Typical power consumption, Bluetooth Low Energy (CPU sleep enabled)**

## 11 RF Characteristics

### 11.1 Supported frequencies and channels

Parameter	Min	Max	Unit
Frequency	2402	2480	MHz
Channels	0	78	CH #

Table 15 Supported frequencies and channels

### 11.2 Typical receiver sensitivity

Packet type	-40 to 85°C	Unit
DH1	-95	dBm
2DH1	-96	dBm
3DH3	-88	dBm
LE	-96	dBm

Table 16 Typical receiver sensitivity

### 11.3 Transmitter output power

Modulation type	Min	Typ	Max	Unit
BDR (1 Mbps)	10	12	14	dBm
EDR (2, 3 Mbps)	7	9	11	dBm
LE	5.5	7	8.5	dBm

Table 17 Transmitter output power at maximum setting

### 11.4 Carrier frequency accuracy

Parameter	Typ	Max	Bluetooth limit (total error)	Unit
Variation between individual units	3	10	+/- 25	ppm
Variation with temperature (-40 to +85°C)	9	15	+/- 25	ppm

Table 18 Carrier frequency accuracy

## 12 Physical dimensions

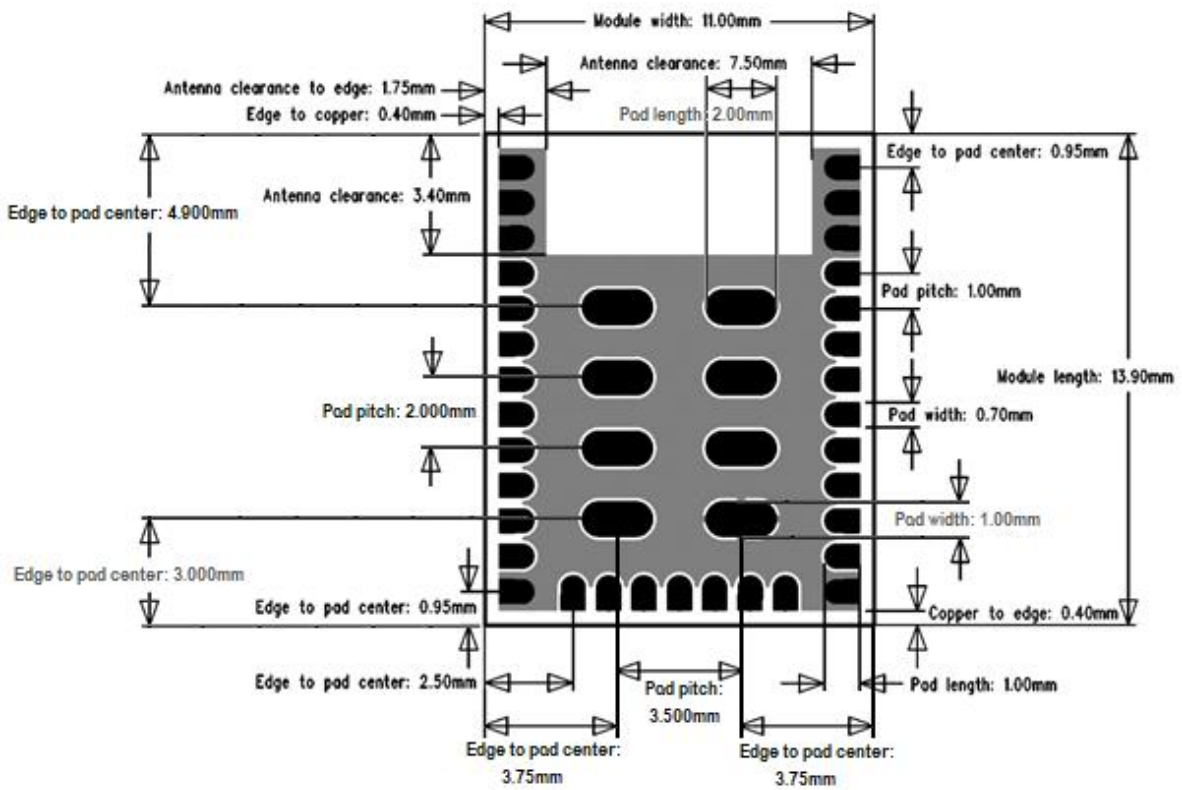

Figure 22 BT121 module physical dimensions

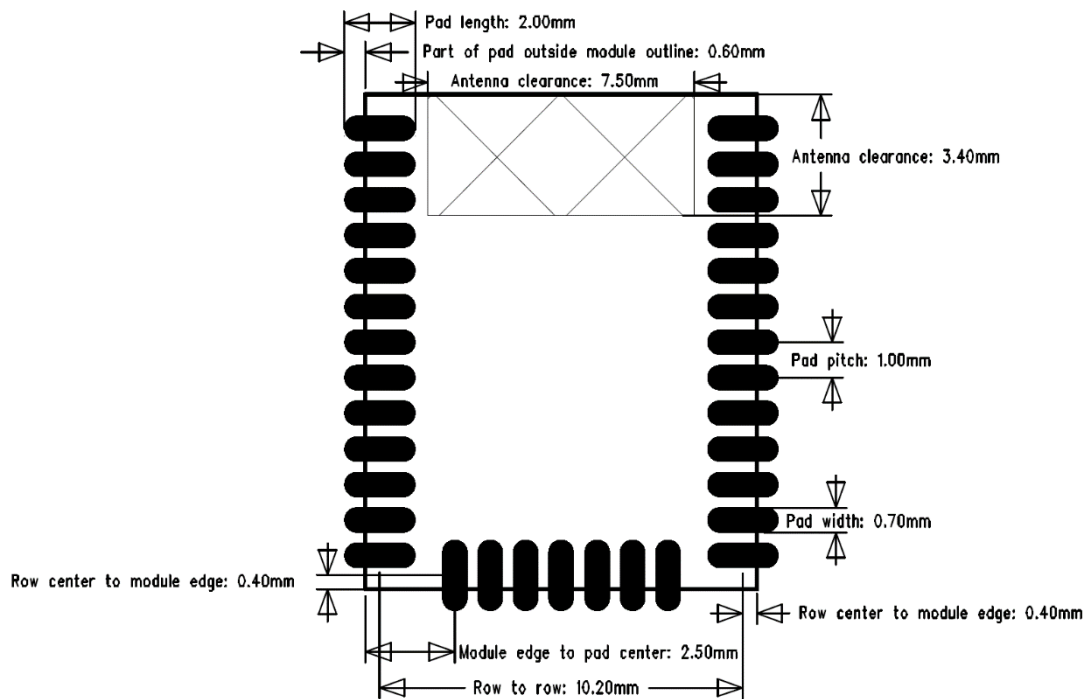

Figure 23 BT121 module recommended PCB pad pattern



The 8 center pins of the module are reserved for production programming and testing and should be left unsoldered but despite of this unmasked traces and vias should NOT be placed under the module in order to prevent short circuits.

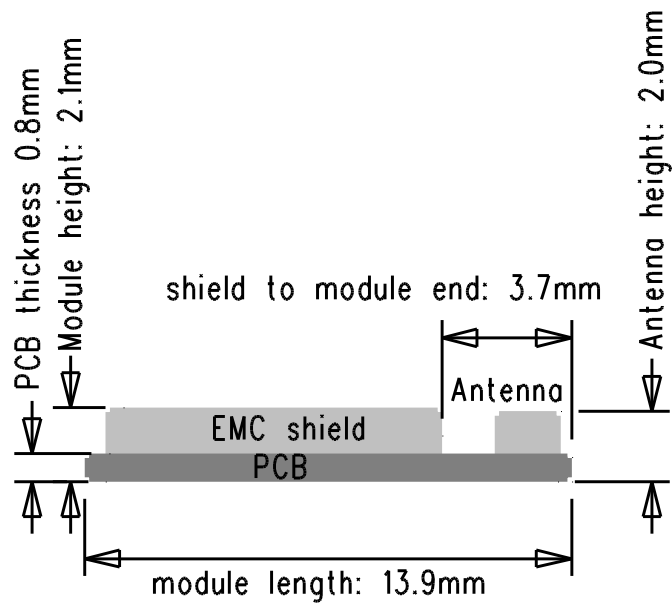

Figure 24 BT121 module side view dimensions

## 13 Soldering recommendations

Bluegiga *Bluetooth* Dual Mode module BT121 is compatible with the industrial standard reflow profile for Pb-free solders. The reflow profile to be used depends on the thermal mass of the entire populated application PCB, heat transfer efficiency of the oven and on the particular type of solder paste used. Consult the datasheet of the particular solder paste used for more detailed information regarding profile configurations.

The following recommendations for soldering the module are to ensure reliable solder joints and operation of the module after soldering. Since the soldering profile used is process and layout dependent, the optimum profile should be studied and decided case by case.

The following recommendation should be taken only as a starting point and should be adjusted according to more detailed instructions of the solder paste and soldering equipment manufacturers.

- Check the recommended soldering profile configuration from the solder paste manufacturers documentation.
- Avoid using more than one flow.
- Reliability of the solder joints and self-alignment of the component are dependent on the solder volume. A minimum stencil thickness of 150  $\mu\text{m}$  is recommended.
- Aperture size of the stencil should be 1:1 with the pad size.
- A low residue, “no clean” solder paste should be used due to the low mounted height of the module.
- If the vias used on the application board have a diameter larger than 0.3 mm, it is recommended to mask the via holes at the module side to prevent solder wicking through the via holes. Solders have a habit of filling holes and leaving voids in the thermal pad solder junction, as well as forming solder balls on the other side of the application board. These phenomena can in some cases cause problems.

## 13.1 Soldering profile example

As an example of a typical soldering profile please see an example of a generic example of a reflow profile shown below. As stated in previous section soldering profiles are solder paste specific. Consult the manufacturer of the paste used.

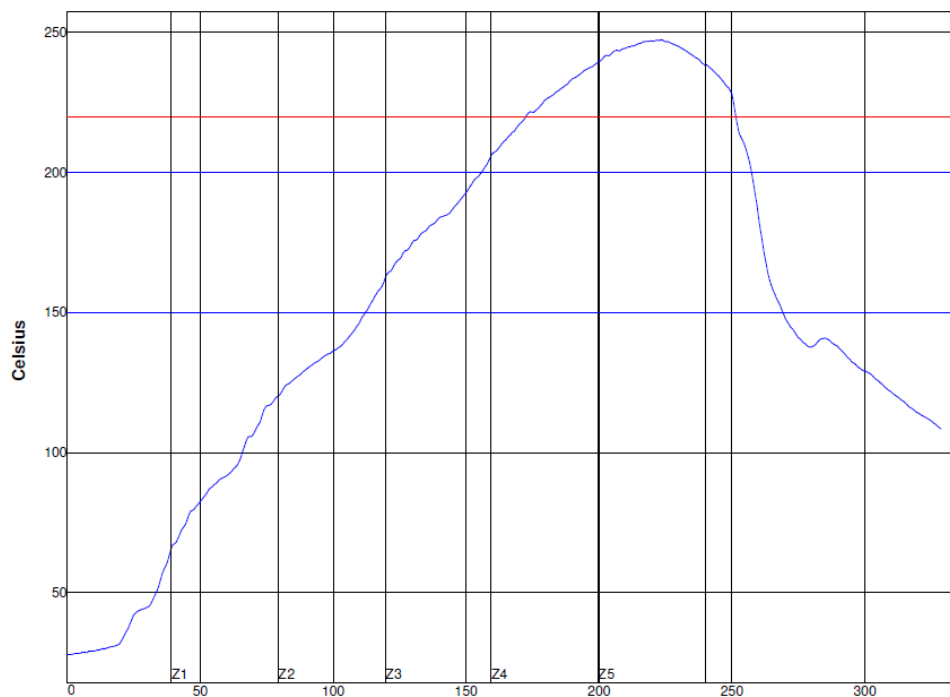

**Figure 25 Reference reflow profile example**

## 14 Tape and reel packaging

This section contains information regarding the tape and reel packaging and materials of packaging with dimensions for the Bluegiga *Bluetooth* Dual Mode BT121 module.

### 14.1 Reel material and dimensions

- Reel material PS Conductive Black – surface resistance 103 ↔ 105
- Reel diameter 13"
- Reel color Black

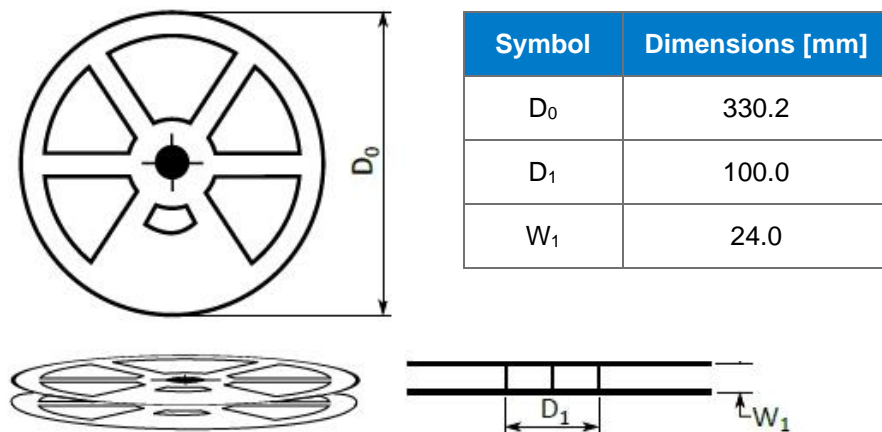

Table 19 Reel dimensions

### 14.2 Tape material and dimensions

- Tape material PS Conductive Black – surface resistance 103 ↔ 105

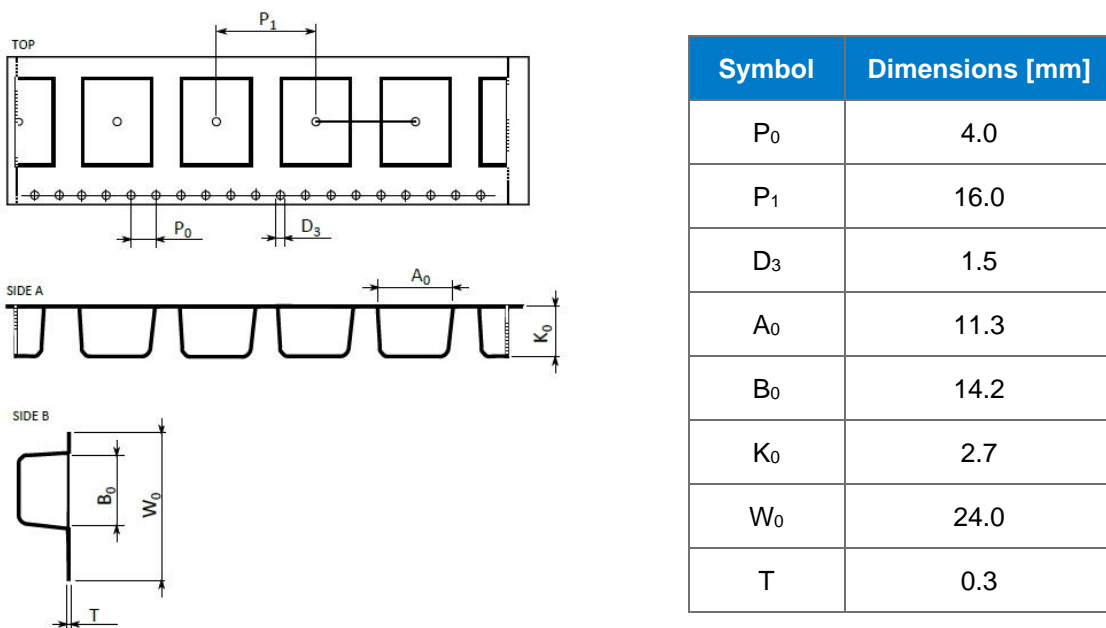
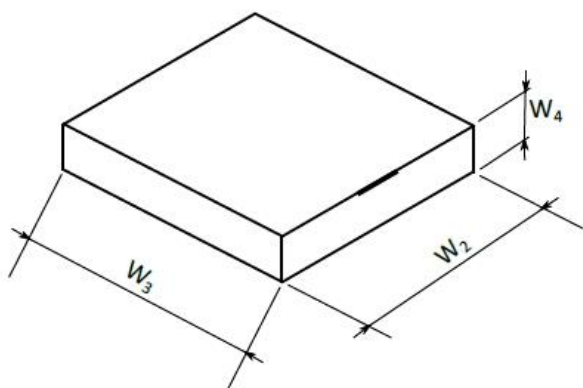

Table 20 Tape dimensions

### 14.3 Tape and reel box dimensions



Symbol	Dimensions [mm]
W <sub>1</sub>	338
W <sub>2</sub>	344
W <sub>3</sub>	44

Table 21 Tape and reel box dimensions

### 14.4 Module orientation in tape

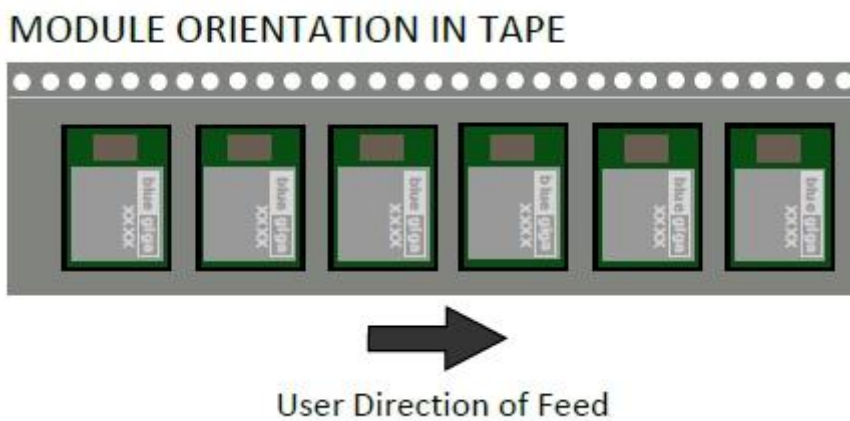

Figure 26 Module orientation in tape and feed direction

## 15 Certifications

### 15.1 Bluetooth

The Bluetooth declaration ID for BT121 hardware is: D027374

The Bluetooth declaration ID for Bluetooth Dual Mode software is: D027373

### 15.2 CE

BT121 is in conformity with the essential requirements and other relevant requirements of the R&TTE Directive (1999/5/EC). The official DoC is downloadable from the product web sites ([www.silabs.com](http://www.silabs.com)).

### 15.3 FCC

This device complies with Part 15 of the FCC Rules. Operation is subject to the following two conditions:

- (1) this device may not cause harmful interference, and
- (2) this device must accept any interference received, including interference that may cause undesired operation.

Any changes or modifications not expressly approved by Bluegiga Technologies could void the user's authority to operate the equipment.

#### **FCC RF Radiation Exposure Statement:**

This equipment complies with FCC radiation exposure limits set forth for an uncontrolled environment. End users must follow the specific operating instructions for satisfying RF exposure compliance. This transmitter meets both portable and mobile limits as demonstrated in the RF Exposure Analysis. This transmitter must not be co-located or operating in conjunction with any other antenna or transmitter except in accordance with FCC multi-transmitter product procedures.

As long as the condition above is met, further transmitter testing will not be required. However, the OEM integrator is still responsible for testing their end-product for any additional compliance requirements required with this module installed (for example, digital device emissions, PC peripheral requirements, etc.).

#### **OEM Responsibilities to comply with FCC Regulations**

The BT121 Module has been certified for integration into products only by OEM integrators under the following conditions:

- The antenna(s) must be installed such that a minimum separation distance of 7 mm is maintained between the radiator (antenna) and all persons at all times.
- The transmitter module must not be co-located or operating in conjunction with any other antenna or transmitter except in accordance with FCC multi-transmitter product procedures.

As long as the two conditions above are met, further transmitter testing will not be required. However, the OEM integrator is still responsible for testing their end-product for any additional compliance requirements required with this module installed (for example, digital device emissions, PC peripheral requirements, etc.).

**IMPORTANT NOTE:** In the event that these conditions cannot be met (for certain configurations or co-location with another transmitter), then the FCC authorization is no longer considered valid and the FCC ID cannot be used on the final product. In these circumstances, the OEM integrator will be responsible for re-evaluating the end product (including the transmitter) and obtaining a separate FCC authorization.

## End Product Labeling

The BT121 module is labeled with its own FCC ID. If the FCC ID is not visible when the module is installed inside another device, then the outside of the device into which the module is installed must also display a label referring to the enclosed module. In that case, the final end product must be labeled in a visible area with the following:

**“Contains Transmitter Module FCC ID: QOQBT121”**

or

**“Contains FCC ID: QOQBT121”**

The OEM integrator has to be aware not to provide information to the end user regarding how to install or remove this RF module or change RF related parameters in the user manual of the end product.

## 15.4IC

This radio transmitter (IC: 5123A-BGTBT121) has been approved by Industry Canada to operate with the embedded chip antenna. Other antenna types are strictly prohibited for use with this device.

This device complies with Industry Canada’s license-exempt RSS standards. Operation is subject to the following two conditions:

- (1) This device may not cause interference; and
- (2) This device must accept any interference, including interference that may cause undesired operation of the device

## RF Exposure Statement

Exception from routine SAR evaluation limits are given in RSS-102 Issue5. BT121 meets the given requirements when the minimum separation distance to human body is less than equal to 20 mm. RF exposure or SAR evaluation is not required when the separation distance is 20 mm or more. If the separation distance is less than 20 mm the OEM integrator is responsible for evaluating the SAR.

## OEM Responsibilities to comply with IC Regulations

The BT121 Module has been certified for integration into products only by OEM integrators under the following conditions:

- The antenna(s) must be installed such that a minimum separation distance of 20 mm is maintained between the radiator (antenna) and all persons at all times.
- The transmitter module must not be co-located or operating in conjunction with any other antenna or transmitter.

As long as the two conditions above are met, further transmitter testing will not be required. However, the OEM integrator is still responsible for testing their end-product for any additional compliance requirements required with this module installed (for example, digital device emissions, PC peripheral requirements, etc.).

**IMPORTANT NOTE:** In the event that these conditions cannot be met (for certain configurations or co-location with another transmitter), then the IC authorization is no longer considered valid and the IC ID cannot be used on the final product. In these circumstances, the OEM integrator will be responsible for re-evaluating the end product (including the transmitter) and obtaining a separate IC authorization

## End Product Labeling

The BT121 module is labeled with its own IC ID. If the IC ID is not visible when the module is installed inside another device, then the outside of the device into which the module is installed must also display a label referring to the enclosed module. In that case, the final end product must be labeled in a visible area with the following:

**“Contains Transmitter Module IC: 5123A-BGTBT121”**

or

**“Contains IC: 5123A-BGTBT121”**

The OEM integrator has to be aware not to provide information to the end user regarding how to install or remove this RF module or change RF related parameters in the user manual of the end product

### 15.4.1 IC (français)

Cet émetteur radio (IC : 5123A-BGTBT121) a reçu l'approbation d'Industrie Canada pour une exploitation avec l'antenne puce incorporée. Il est strictement interdit d'utiliser d'autres types d'antenne avec cet appareil.

Le présent appareil est conforme aux CNR d'Industrie Canada applicables aux appareils radio exempts de licence. L'exploitation est autorisée aux deux conditions suivantes :

- 1) l'appareil ne doit pas produire de brouillage;
- 2) l'utilisateur de l'appareil doit accepter tout brouillage radioélectrique subi, même si le brouillage est susceptible d'en compromettre le fonctionnement.

### Déclaration relative à l'exposition aux radiofréquences (RF)

Les limites applicables à l'exemption de l'évaluation courante du DAS sont énoncées dans le CNR 102, 5<sup>e</sup> édition. L'appareil BT121 répond aux exigences données quand la distance de séparation minimum par rapport au corps humain est inférieure ou égale à 20 mm. L'évaluation de l'exposition aux RF ou du DAS n'est pas requise quand la distance de séparation est de 20 mm ou plus. Si la distance de séparation est inférieure à 20 mm, il incombe à l'intégrateur FEO d'évaluer le DAS.

### Responsabilités du FEO ayant trait à la conformité avec les règlements IC

Le module BT121 a été certifié pour une intégration dans des produits uniquement par les intégrateurs FEO dans les conditions suivantes :

- La ou les antennes doivent être installées de telle façon qu'une distance de séparation minimum de 20 mm soit maintenue entre le radiateur (antenne) et toute personne à tout moment.
- Le module émetteur ne doit pas être installé au même endroit ou fonctionner conjointement avec toute autre antenne ou émetteur.

Dès lors que les deux conditions ci-dessus sont respectées, d'autres tests de l'émetteur ne sont pas obligatoires. Cependant, il incombe toujours à l'intégrateur FEO de tester la conformité de son produit final vis-à-vis de toute exigence supplémentaire avec ce module installé (par exemple, émissions de dispositifs numériques, exigences relatives aux matériels périphériques PC, etc).

**REMARQUE IMPORTANTE :** S'il s'avère que ces conditions ne peuvent être respectées (pour certaines configurations ou la colocation avec un autre émetteur), alors l'autorisation IC n'est plus considérée comme valide et l'identifiant IC ne peut plus être employé sur le produit final. Dans ces circonstances, l'intégrateur FEO aura la responsabilité de réévaluer le produit final (y compris l'émetteur) et d'obtenir une autorisation IC distincte.

## Étiquetage du produit final

L'étiquette du module BT121 porte son propre identifiant IC. Si l'identifiant IC n'est pas visible quand le module est installé à l'intérieur d'un autre appareil, l'extérieur de l'appareil dans lequel le module est installé doit aussi porter une étiquette faisant référence au module qu'il contient. Dans ce cas, une étiquette comportant les informations suivantes doit être collée sur une partie visible du produit final :

« **Contient le module émetteur IC : 5123A-BGTBT121** »

ou

« **Contient IC : 5123A-BGTBT121** »

L'intégrateur FEO doit être conscient de ne pas fournir d'informations à l'utilisateur final permettant d'installer ou de retirer ce module RF ou de changer les paramètres liés aux RF dans le mode d'emploi du produit final.

## 15.5 MIC Japan

BT121 is certified in Japan with certification number 209-J00171.

Since September 1, 2014 it is allowed (and highly recommended) that a manufacturer who integrates a radio module in their host equipment can place the certification mark and certification number (the same marking/number as depicted on the label of the radio module) on the outside of the host equipment. The certification mark and certification number must be placed close to the text in the Japanese language which is provided below. This change in the Radio Law has been made in order to enable users of the combination of host and radio module to verify if they are actually using a radio device which is approved for use in Japan.

当該機器には電波法に基づく、技術基準適合証明等を受けた特定無線設備を装着している。

Translation:

"This equipment contains specified radio equipment that has been certified to the Technical Regulation Conformity Certification under the Radio Law."

## 15.6 KC (South-Korea)

BT121 is certified in South-Korea with certification ID MSIP-CRM-BGT-BT121.

## 16 Ordering information

Product code	Description
BT121-A-V2	BT121 <i>Bluetooth</i> Dual Mode module with an integrated antenna. Mass production version.
BT121-A-V2-iAP	BT121 <i>Bluetooth</i> Dual Mode module with an integrated antenna and Apple iAP profile. This part number is only available to Apple MFI licenses. Mass production version.
BT121-A-V1	BT121 <i>Bluetooth</i> Dual Mode module with an integrated antenna <b>Engineering sample.</b> Not recommended for new designs.
BT121-A-V1-iAP	BT121 <i>Bluetooth</i> Dual Mode module with an integrated antenna and Apple iAP profile. This part number is only available to Apple MFI licenses. <b>Engineering sample.</b> Not recommended for new designs.
DKBT	Bluegiga <i>Bluetooth</i> Dual Mode Development kit

# Simplicity Studio

One-click access to MCU and wireless tools, documentation, software, source code libraries & more. Available for Windows, Mac and Linux!



**IoT Portfolio**

[www.silabs.com/IoT](http://www.silabs.com/IoT)



**SW/HW**

[www.silabs.com/simplicity](http://www.silabs.com/simplicity)



**Quality**

[www.silabs.com/quality](http://www.silabs.com/quality)



**Support & Community**

[www.silabs.com/community](http://www.silabs.com/community)

## Disclaimer

Silicon Labs intends to provide customers with the latest, accurate, and in-depth documentation of all peripherals and modules available for system and software implementers using or intending to use the Silicon Labs products. Characterization data, available modules and peripherals, memory sizes and memory addresses refer to each specific device, and "Typical" parameters provided can and do vary in different applications. Application examples described herein are for illustrative purposes only. Silicon Labs reserves the right to make changes without further notice to the product information, specifications, and descriptions herein, and does not give warranties as to the accuracy or completeness of the included information. Without prior notification, Silicon Labs may update product firmware during the manufacturing process for security or reliability reasons. Such changes will not alter the specifications or the performance of the product. Silicon Labs shall have no liability for the consequences of use of the information supplied in this document. This document does not imply or expressly grant any license to design or fabricate any integrated circuits. The products are not designed or authorized to be used within any FDA Class III devices, applications for which FDA premarket approval is required, or Life Support Systems without the specific written consent of Silicon Labs. A "Life Support System" is any product or system intended to support or sustain life and/or health, which, if it fails, can be reasonably expected to result in significant personal injury or death. Silicon Labs products are not designed or authorized for military applications. Silicon Labs products shall under no circumstances be used in weapons of mass destruction including (but not limited to) nuclear, biological or chemical weapons, or missiles capable of delivering such weapons. Silicon Labs disclaims all express and implied warranties and shall not be responsible or liable for any injuries or damages related to use of a Silicon Labs product in such unauthorized applications.

## Trademark Information

Silicon Laboratories Inc.®, Silicon Laboratories®, Silicon Labs®, SiLabs® and the Silicon Labs logo®, Bluegiga®, Bluegiga Logo®, ClockBuilder®, CMEMS®, DSPLL®, EFM®, EFM32®, EFR, Ember®, Energy Micro, Energy Micro logo and combinations thereof, "the world's most energy friendly microcontrollers", Ember®, EZLink®, EZRadio®, EZRadioPRO®, Gecko®, Gecko OS, Gecko OS Studio, ISOModem®, Precision32®, ProSLIC®, Simplicity Studio®, SiPHY®, Telegesis, the Telegesis Logo®, USBXpress®, Zentri, the Zentri logo and Zentri DMS, Z-Wave®, and others are trademarks or registered trademarks of Silicon Labs. ARM, CORTEX, Cortex-M3 and THUMB are trademarks or registered trademarks of ARM Holdings. Keil is a registered trademark of ARM Limited. Wi-Fi is a registered trademark of the Wi-Fi Alliance. All other products or brand names mentioned herein are trademarks of their respective holders.



Silicon Laboratories Inc.  
400 West Cesar Chavez  
Austin, TX 78701  
USA

<http://www.silabs.com>